

TOP WIRE

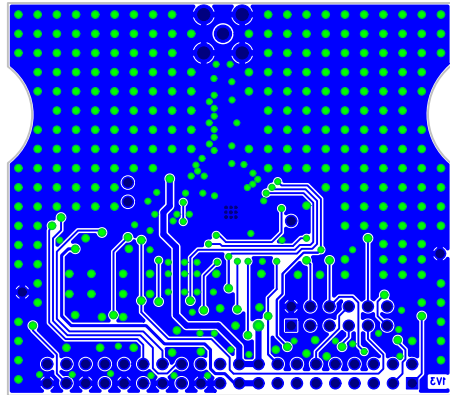

BOTTOM WIRE

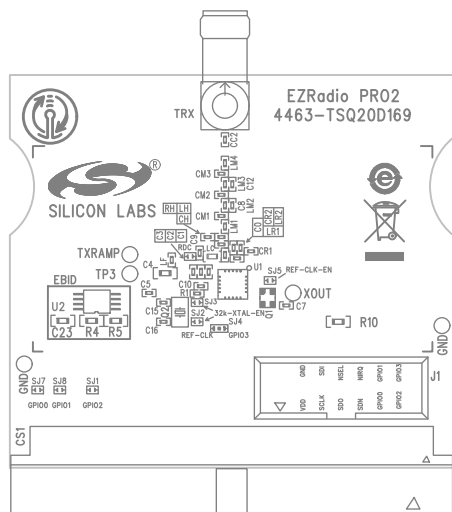

TOP ASSEMBLY
TOP SILKSCREEN

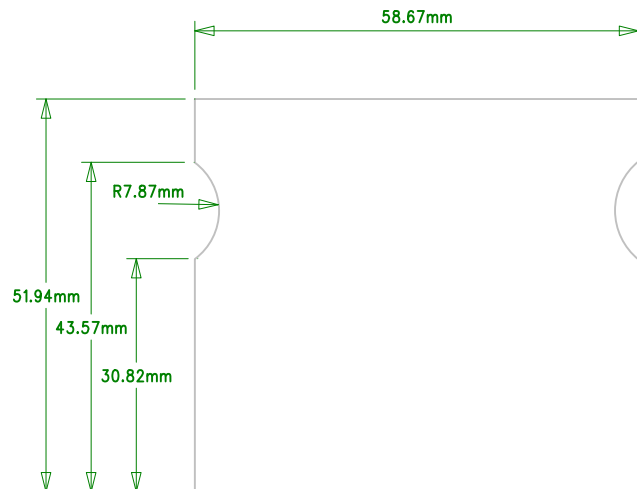

MANUFACTURING NOTES: (UNLESS OTHERWISE SPECIFIED)

1. MATERIAL: COPPER CLAD EPOXY GLASS FR-4 BASE MATERIAL.
COPPER CLADDING SHALL BE TYPE "HTE" WITH A WEIGHT OF 1/2 OZ/SQ FT. FOR EXTERNAL LAYERS AND 1/2 OZ/SQ FT. FOR INTERNAL LAYERS AND/OR PLANES.
MINIMUM WEIGHT AFTER PLATING OF EXTERNAL LAYERS SHALL BE 1 OZ/SQ FT.
2. TOTAL BOARD THICKNESS SHALL BE 1.63 +/- 0.15 mm. LAYER SEQUENCING SHALL BE CONSECUTIVE AS ESTABLISHED BY THE MASTER PATTERN LAYER SCHEDULE SHOWN.
3. LAYER TO LAYER REGISTRATION OF THE CONDUCTOR PATTERNS SHALL BE WITHIN 0.10 mm DIA. TRUE POSITION, WITH AN ABSOLUTE MINIMUM OF 0.05 mm BETWEEN PLATED-THRU HOLE WALLS AND ADJACENT CONDUCTIVE SURFACES. END PRODUCT LINE WIDTH AND TERMINAL AREAS SHALL NOT DEVIATE FROM THE 1:1 MASTER PATTERN IMAGE BY MORE THAN +0.025 mm, -0.075 mm FOR 1/2 OZ. COPPER.
4. ALL PLATED-THROUGH HOLES TO HAVE A MINIMUM COPPER WALL THICKNESS OF 0.025 mm. PLATING SHALL BE CONTINUOUS. DO NOT FILL VIAS
5. HOLE SIZE TOLERANCES SHALL BE:
PLATED-THROUGH HOLES > 0.50 mm SHALL BE +/- 0.075 mm.
UNPLATED THROUGH HOLES SHALL BE +/- 0.05 mm.
TOLERANCES APPLY AFTER PLATING.
6. FINISH: GOLDPLATED ON FOOTPRINTS AND PADS 0.0002 mm MAX.
7. SOLDERMASK: SOLDERMASK OVER BARE COPPER - COLOR : BLUE
8. SILKSCREEN: SILKSCREEN TOP SIDE ONLY USING NON-CONDUCTIVE WHITE EPOXY INK.
9. THE PCB WARP AND TWIST SHALL NOT EXCEED 1 %
10. HOLE TO EDGE TOLERANCE SHALL NOT VARY MORE THAN +/- 0.25 mm.
11. ALL TOLERANCES ARE NON-ACCUMULATIVE.
12. ALL 1.27 mm TRACES ON LAYER 1 OR LAYER 2 ARE 50 OHM +/- 5 OHM IMPEDANCE CONTROLLED TRACES. IMPEDANCE CALCULATIONS ARE MADE ASSUMING A DIELECTRIC CONSTANT OF 4.6 FOR CRITICAL PRE-PREG LAYER. IF DIELECTRIC CONSTANT IS NOT 4.6 VENDOR SHALL ADJUST TRACE WIDTH TO ACHIEVE 50 OHMS.

THICKNESS* DENOTES MAXIMUM VALUE

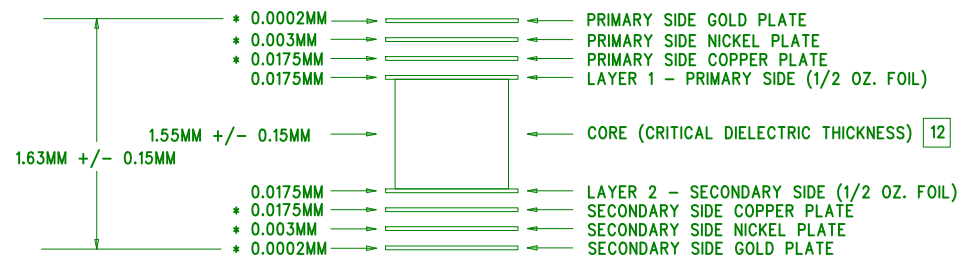

LAYER SCHEDULE

SCALE: NONE 2